

Uniform Semi-Automatic, Top and Bottom Case Sealer

STA-320

S E R I E S

- Most cost effective system
- Built for reliability
- 2" Taping
- 85 FPM belt speed
- Heavy duty casters
- Motor overload protection
- Heavy duty frame
- Heavy duty transmission system
- Top flap compression rollers are standard
- ABC System is standard



APPLICATION

The STA-320 is a modular designed uniform bottom belt case sealing machine. After the top flaps are closed, the box will enter the sealer and tape both the top and bottom of the box with pressure sensitive tape. There is no limit to the length of the box and the machine can handle a maximum width and height of 20.50 inches.

Designed for heavy duty applications, all timing belts have been eliminated and with the combination of our ABC System (Automatic Belt Cut-Off), maintenance is kept to a minimum.

With the one-sided mast, the user has the flexibility of placing a label making machine to complete their packaging system.

EXCLUSIVE STA TAPE HEAD

The patented STA taping head design is uniquely engineered to maintain consistent pressure to the tape to ensure the most secure, reliable seal possible. Our new line of interchangeable pressure sensitive taping heads are offered in a variety of tab lengths and tape widths to fit your application.

For the best results, rely on STA Proven Performance acrylic tapes, for use with your high-throughput sealing machines. Together, you have the most reliable single source tape sealing system.





STA-320

SERIES

Uniform Semi Automatic,
Top and Bottom Case Sealer

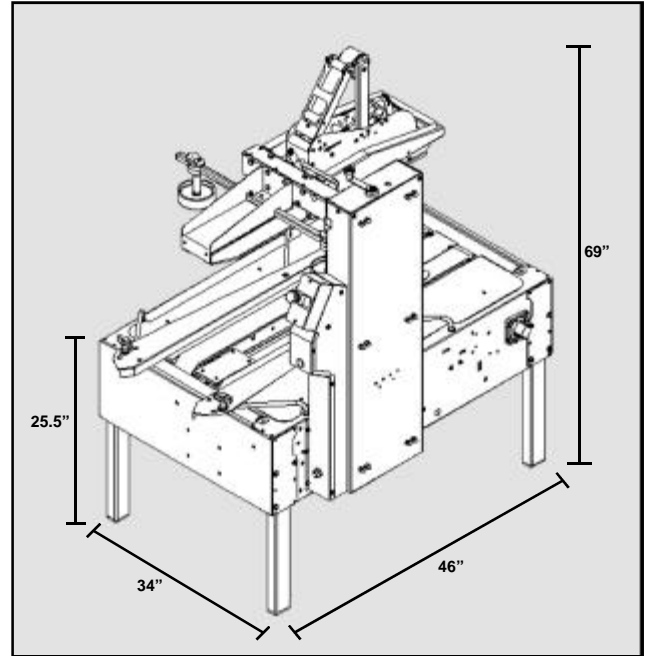

TAPE

- SUPREME
- SILENT SUPREME™
- EASY RELEASE™
- NATURAL RUBBER
- PRINTED
- COLORS
- RETAIL ROLL
- LABEL PROTECTION
- STATIONERY
- UPVC
- MASKING
- STRAPPING
- FILAMENT
- WATER ACTIVATED REINFORCED AND GUMMED PAPER

DISPENSERS

- HAND DISPENSERS
- NOISE REDUCING DISPENSERS
- BENCH DISPENSERS

MACHINES

- UNIFORM SEMI-AUTOMATIC CASE SEALERS
- UNIFORM AUTOMATIC CASE SEALERS
- RANDOM SEMI-AUTOMATIC CASE SEALERS
- RANDOM AUTOMATIC CASE SEALERS
- PACKING STATIONS
- CASE ERECTORS
- INTERCHANGEABLE TAPE HEADS

ACCESSORIES

- PACKING TABLES & STATIONS
- CASTERS
- THREE FLAPS CLOSERS
- BOX BLOCKING SYSTEM

SPECIFICATIONS

Model Number	Tape Width	Tab Length	Length Min. - Max.*	Width Min. - Max.*	Height Min. - Max.*
STA320	2"	2"	5.90" - Unlimited	5.25" - 20.50"	4.00" - 20.50"
STA32021	2"	1"	5.90" - Unlimited	5.25" - 20.50"	2.36" - 20.50"
STA32023	2"	3"	5.90" - Unlimited	5.25" - 20.50"	4.69" - 20.50"

*Recommended carton specifications may vary

Power Requirements:	110V / 60Hz / 1PH
Tape Width:	2-in., 3-in.
Maximum Case Weight:	100 lbs.
Minimum Case Weight:	7 lbs.
Belt Speed:	85 FPM
Machine Dimensions:	(LxWxH) 46" x 34" x 69"
Shipping Dimensions:	(LxWxH) 46" x 41" x 41"
Machine Weight:	324 lbs.
Shipping Weight:	353 lbs.

Authorized STA Packaging Tapes Distributor:

Specifications are subject to change without notice. Printed in the U.S.A. All trademarks and registered trademarks are property of Sekisui TA Industries, Inc.